

Issue D

LMS 150 Two Speed
Owner's Installation, Operation & Basic Servicing Manual

GB

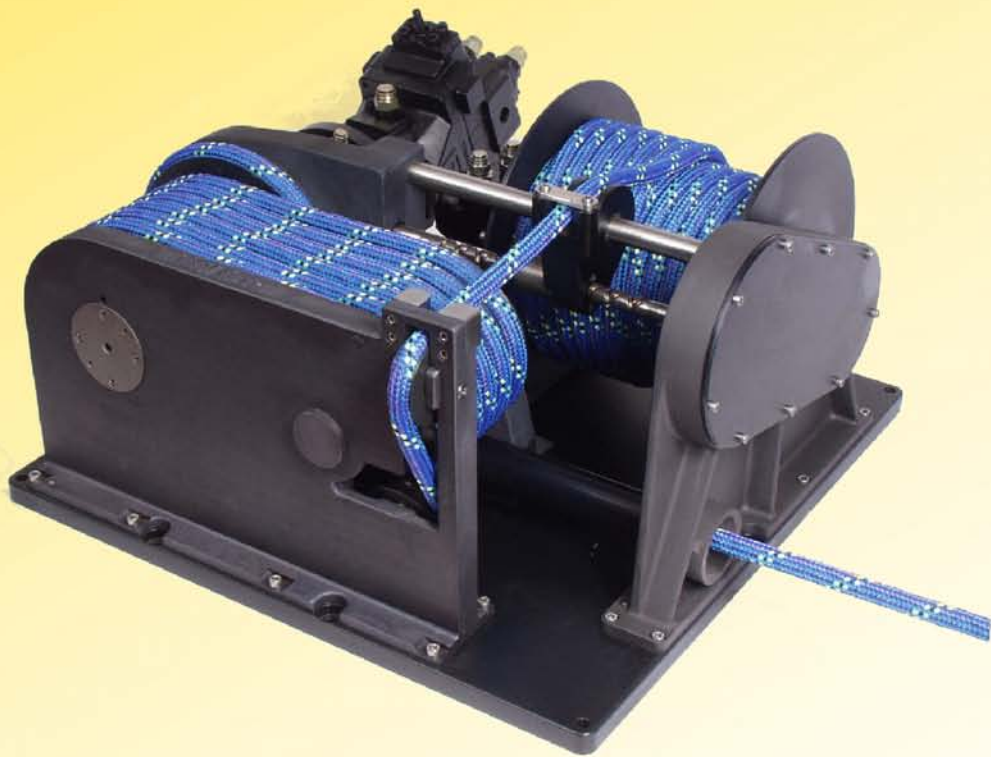

LEWMAR®

www.lewmar.com



INTRODUCTION

The Lewmar Line Management system LMS150 Winch is a hydraulic powered self-contained winch, offering significant and desirable advantages over other captive winches currently available.

It has been designed to suit the needs of large cruising yachts, where highly loaded sheets need to be stowed quickly and safely with the minimum of fuss or effort.

The LMS150 Winch comprises of two elements, a hauling section and a stowing section, mounted on a common base plate. The design of the hauling section helps eliminate rope damage caused by friction on the highly loaded traction drive unit by employing a separate idler drum around which the line is fed. The idler drum is positioned so as to provide a perfect lead, allowing the rope to be stored neatly at low tension preventing damage to the rope and eliminating the possibility of riding turns.

The line is then stored at low tension on the separate stowing drum.

The hauling section employs an efficient two speed automatic gearbox giving good spread of line speed with minimum power demand. A choice of control systems enables the winch to be used in fixed speed or fully proportional modes.

The LMS150 Winch also eliminates long entry lead angles with its ability to be close coupled to the point of sheet entry.

The LMS150 is fitted with a High Load release system and an optional auto pay out.

This plus the simple hydraulic connections ensures that the LMS150 Winch occupies only the minimum of precious space on today's complex yachts.



SPECIFICATION

Line Diameter Range

28mm Diameter, specified at time of purchase.

Stowing Unit: Stowing Capacity

28mm Diameter Line - 20 Meters

Electrical Requirements

24 V DC + / - 15%

5.0 Amps Maximum

Hydraulic Requirements

Maximum Flow 60 Litres / Min

Maximum Pressure "A" & "B" 210 Bar

Maximum Pressure "Drain" 4 Bar

Hydraulic Fluid - Mineral Oil Confirming to ISO 3448 (BS 4231)

Viscosity Grade 32, Type HM

Filtered to cleanliness standard ISO 4406 (BS 5540) Class 18 / 13 or better.

Fluid optimum operating temperature range 20 °C to 50 °C

Line Speed @ 60 l/min

First Gear (High speed) 28 Meters / Min

Second Gear (Low speed) 7 Meters / Min

Maximum Line Pull

First Gear (Low Torque) 2000 Kg @ 180 Bar

Second Gear (High Torque) 12000 Kg @ 210 Bar

NOTE: The winch automatically changes from first (high) gear to second (low) gear when the load causes the hydraulic pressure to rise above 180 Bar.

Unit Overall Dimensions

1060mm x 1035mm x 575mm

Unit Weight

530 Kg

INSTALLATION

UNPACKING

Care must be taken when unpacking the LMS150 winch. If lifting tackle is used, ensure that it cannot inflict damage to the winch. When lifting, use a soft strop positioned around the base plate or the main winch drums only, do not allow the lifting strop to contact any other part of the winch especially the ball reverser.

Do not use wire rope for lifting.

INSTALLATION

Reference drawing No 59500019_2.

A flat pad or area to suit the winch base plate must be provided. Ideally this pad should be flat to within 1 mm. The 14 x 12mm base bolts should be tightened to a torque of 40 to 45 lbf / ft (54 to 61 NM). A working should be available around the winch to facilitate installation, hydraulic connections, and future maintenance see Drawing 59500019_3 & 59500019_4 for details.

HYDRAULIC CONNECTIONS

Reference drawing Nos. 51000325 (Hydraulic Circuit), 58300829 (Manifold Block) & 59500019_4 (LMS Connections).

The winch manifold block is supplied with male connections of JIC type, manifold block numbers are stamped on the top face for identification.

All hose fittings are stamped with identifications relevant to the hydraulic installation drawing 51000325.

Hose ends should be of the straight type or 90 degree swept (90 degree bent tube) type to minimise pressure drop loss. Avoid the use of 90-degree elbows or sharp bends - a minimum bend radius of 150 mm (6") is recommended.

If the hose length is greater than approximately 7 m (20 ft) then a hose with a larger inside diameter should be used to minimise pressure drop loss.

All hoses should be suitable for a safe working pressure of 140 Bar minimum.

Wherever possible use hoses ends of the crimped or swaged type in preference to the reusable type. Connections "A" and "B" should be connected to the systems appropriate directional control valve ports or to the Lewmar Commander directional control valve "A" and "B" ports - refer to your Commander Manual to determine which of the functions has been allocated to operate the LMS150. The "Drain" connection should be routed directly into the Commander tank drain fitting.

INSTALLATION

***** IMPORTANT *****

When connecting the hydraulic supply, cleanliness is of the utmost importance and the following notes should be observed: -

Do not remove the protective caps on the winch hydraulic connections until absolutely necessary.

Ensure hoses are flushed through to remove any contamination before connecting to the winch.

It is generally acknowledged that over 80% of all hydraulic components failure can be attributed to contamination.

NOTE: When using a Danfoss proportional valve type PVG ensure that the ports are connected the correct way around.

Where the PVG solenoid actuator (type PVEH or PVEM) is fitted on the "B" port end of the valve, connect the valve "B" port to the winch "A" port. Where the PVG solenoid actuator (type PVEH or PVEM) is fitted on the "A" port end of the valve, connect the valve "A" port to the winch "A" port.

ELECTRICAL CONNECTIONS

Refer to drawing 58400667 for electrical wiring details

FITTING THE LINE

Each LMS150 Winch is assembled to suit a specific rope diameter agreed at the time of order. Ensure that the correct diameter rope is to be fitted.

Important: Before fitting the rope, the Stowing Drum Ball Reverser Nut and Sheave Assembly must be correctly aligned.

There are two methods of achieving this.

Method 1 Rotate the stowing drum (by hydraulic power) until the Ball Reverser has traversed to the end of its travel at the end of the drum containing the Rope Stay or Rope Hole. Stop the drum rotation when the Ball Reverser just commences to move away from the end of its travel. This will ensure that the rope lies correctly on the drum and will prevent damage being incurred by the Ball Reverser.

INSTALLATION

FITTING THE LINE CONTINUED

Method 2 Remove the Ball Reverser belt drive cover plate and slide the toothed belt off the Ball Reverser shaft pulley. Rotate the Ball Reverser shaft by hand until the Ball Reverser Nut and Sheave Assembly is just starting to move away from the stowing drum flange containing the Rope Stay or Rope Hole. Refit the Toothed Belt and Cover Plate. The rope may now be passed through the entry tube to the Drive Roller Assembly. Insert the rope between the small Drive Roller and the Large Roller.

Slowly rotate the large drum by hand to feed the rope through ensuring that the rope is passed above the Small Drive Roller Spindle (i.e. between the spindle and the drum). The rope is then passed around the Idle drum and multi groove main drum and sheaves and is secured to the stowing drum by means of the rope stay and nut or pushed into the Rope Hole.

Refer to drawing No 55600173 for the rope path.

NOTE: The LMS150 Winch is fitted as standard with an automatic rope pay - out feature which drives the line off the winch irrespective of the line load when the Winch is in Reel Out Mode.

If this feature is not required then the Drive Roller Tension Screw should be released so as to reduce the contact of the drive roller. This can be seen on drawing no 58600077.

NOTE: High Load Release Function is not affected by the presence or absence of the drive belt.

OPERATION

CONTROLS

Fixed Speed (Non proportional) control: Four position joystick

Proportional Control: Proportional single axis joystick with push button high gear button.

FIXED SPEED (NON PROPORTIONAL) CONTROL

Reeling In: Moving the joystick to its first position engages Low Gear (2nd Gear). Reeling in will commence and continue until either maximum load is reached or the joystick is returned to the neutral position. Moving the joystick to its second position (fully over) will put the winch in High gear (1st Gear) and automatically change to Low Gear (2nd Gear) when the load causes the hydraulic pressure to rise above 180 Bar. Reeling in will continue in Low Gear until the maximum load is reached or the joystick is return to the neutral position. High Gear can only be re-engaged when the load drops below 180 Bar and the joystick is returned to the neutral position and Reeling in is re-selected.

Reeling Out: Moving the joystick to its first position engages low gear until the joystick is returned to neutral or moved to its second position (fully over) which engages High Gear.

Neutral: When the joystick is in its neutral position all the solenoid cells are switched off thereby reducing the power consumption to virtually zero.

PROPORTIONAL CONTROL

Reeling In: Moving the joystick and depressing the High-Speed button engages automatic mode. Reeling-in will now commence in High Gear and automatically change into Low Gear when the load causes the hydraulic pressure to rise above 180 Bar. The reeling-in speed in each gear is proportional to the joystick position-the joystick at the full extent of its travel gives maximum speed. Moving the joystick without depressing the High Speed Button will retain the winch in low gear.

Reeling Out: Moving the joystick in the reel-out direction engages Low Gear and will commence and continue in Low Gear until the joystick is returned to neutral or the High Speed button is depressed. Depressing the High-Speed button selects High Gear. The button must be kept depressed to retain High Gear. Releasing the button returns the unit to Low Gear. The reeling out speed, in both gears, is proportional to the joystick position-the joystick at full extent of its travel gives maximum speed.

OPERATION

High Speed Button: Depressing the High Speed Button engages High Gear and provides high speed operation in both reel in and reel out modes. During Reel-In, high gear is automatically disengaged when the high-speed button is released or the hydraulic system pressure rises above 180 Bar. This button ensures that under heavy sail loads any line adjustment or trimming of the sails is performed at low speed unless otherwise selected.

Neutral: When the joystick is in the neutral position all the solenoid coils are switched off thereby reducing the power consumption to virtually zero.

High Load Release Mode: The LMS150 winch is fitted with a High Load Release function, which releases the winch brakes enabling the load to pay out line. When the High Load Release handle is operated, the LMS150 brakes will be released and the line will pay out until a load in the region of 15% of the maximum pull of the winch is reached. A residual tension of between 6% and 17% will still be applied to the line dependant on the condition of the rope. The High Load Release Mode function is initiated by depressing the lever valve located on the winch manifold block Reference drawing 58300829. The High Load Release feature is a manually operated, self-contained unit and does not require any external supply of hydraulic or electrical power.



SERVICING AND MAINTENANCE

The LMS150 Winch has been designed to provide long and trouble free operation, however as with all Electro-Hydraulic and Mechanical equipment, periodic service and maintenance is required to minimise the risk of unplanned down-time. Because the duty cycle of each installation can be very different, the time period between service checks and maintenance can be difficult to predict, however we would recommend the following:

Regular cleansing of the Drive Roller Assembly to remove dust and fluff deposited from the rope. Periodic cleansing and re-greasing of the Stowing Drum Ball Reverser Screw and Nut Assembly. We would recommend the use of Lewmar Multi Purpose Winch Grease (used sparingly). Periodically check the winch and associated pipe work for hydraulic leaks and inspect the hydraulic hoses for any signs of damage or chafing.

At 12 monthly intervals we would recommend the following:

Remove the Ball Reverser drive cover plate and inspect the Toothed Belt and replace if required.
Check the tightness of the belt pulley central retaining screws.
Inspect the Drive Roller Assembly Toothed Belt and replace if necessary.
Check tightness of the Sheave guard central retaining screws (4 off).
Check the electrical connections on the winch manifold, solenoid valves and pressure switch.

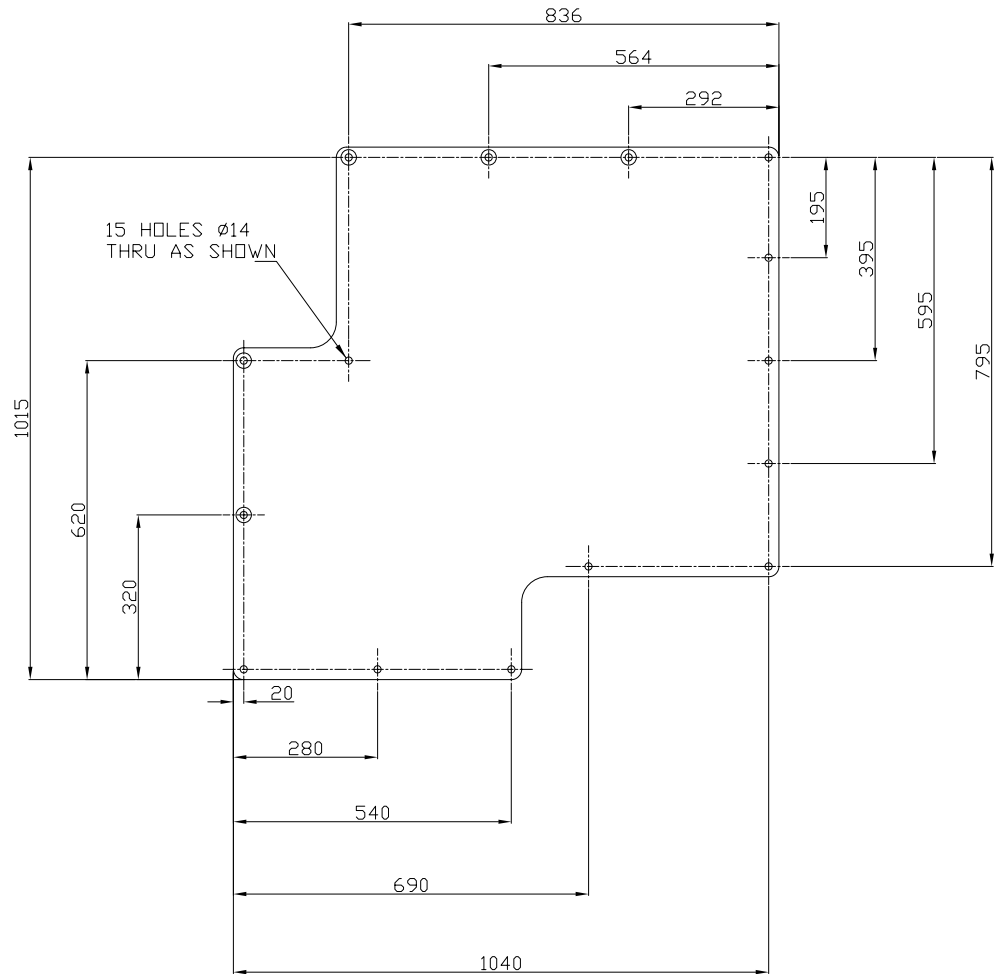
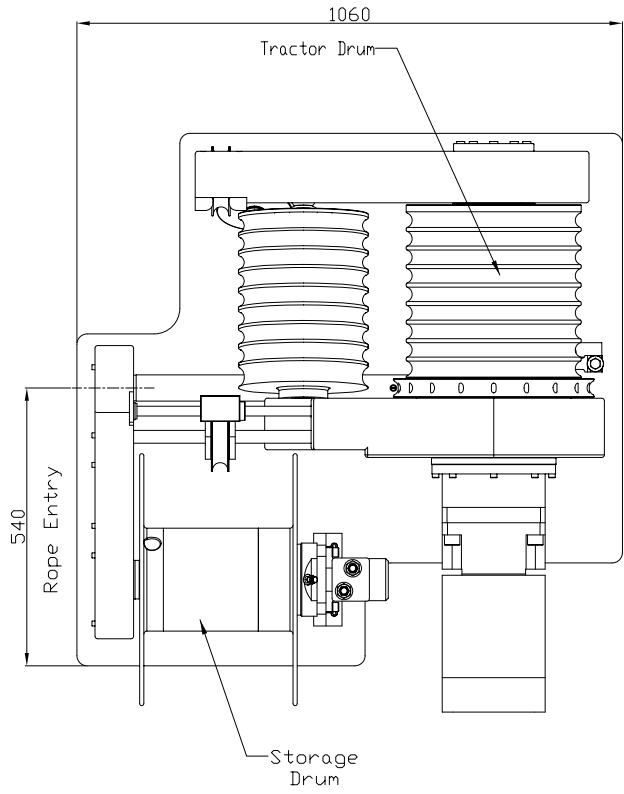
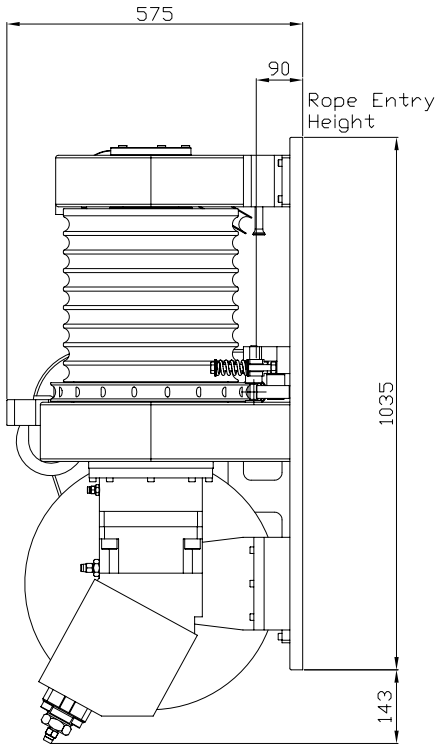

Maximum Line Pull	12,000kg @ 210 bar
Maximum Line Speed In Each Gear	27.5/7 m/min
Line Diameter Size Range	28mm
Line Storage	28mm = 20m
Maximum Working Pressure	210 BAR
Weight	530kg

ISSUE	DATE / NWE	MD No.
A	02.03.06 P.H.	N/A

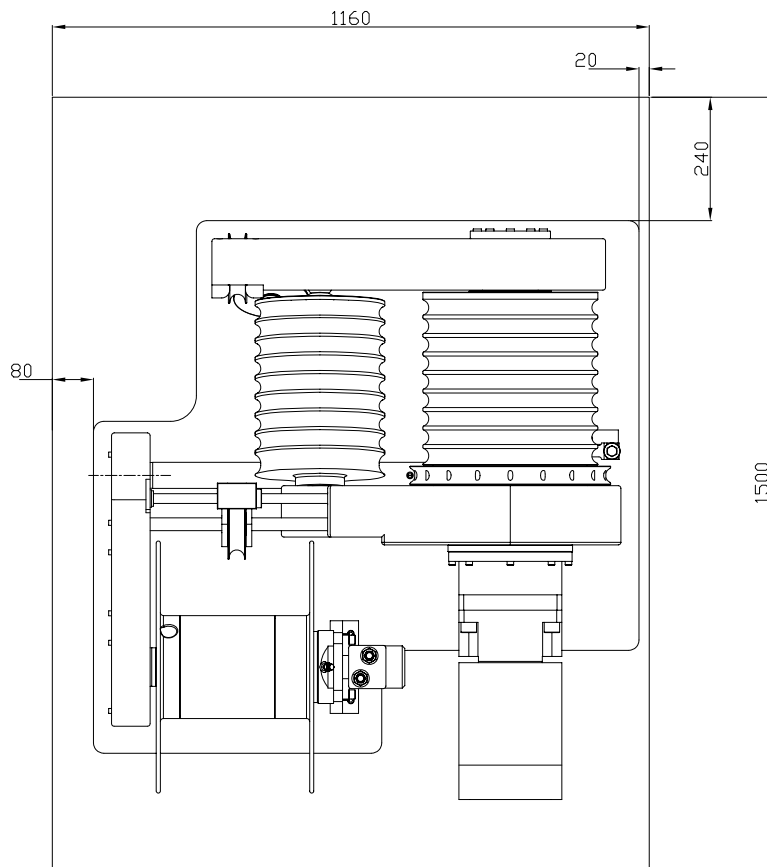

150 LMS/2 MAINTENANCE CLEARANCE

SCALE 1:1
ALL DIMS IN mm

DRN	P.H.
DATE	02.03.06

DRG. No
59500019_3

LEWMAR

ISSUE	DATE / NAME	MOD No.
A	09.05.06 P.H.	N/A

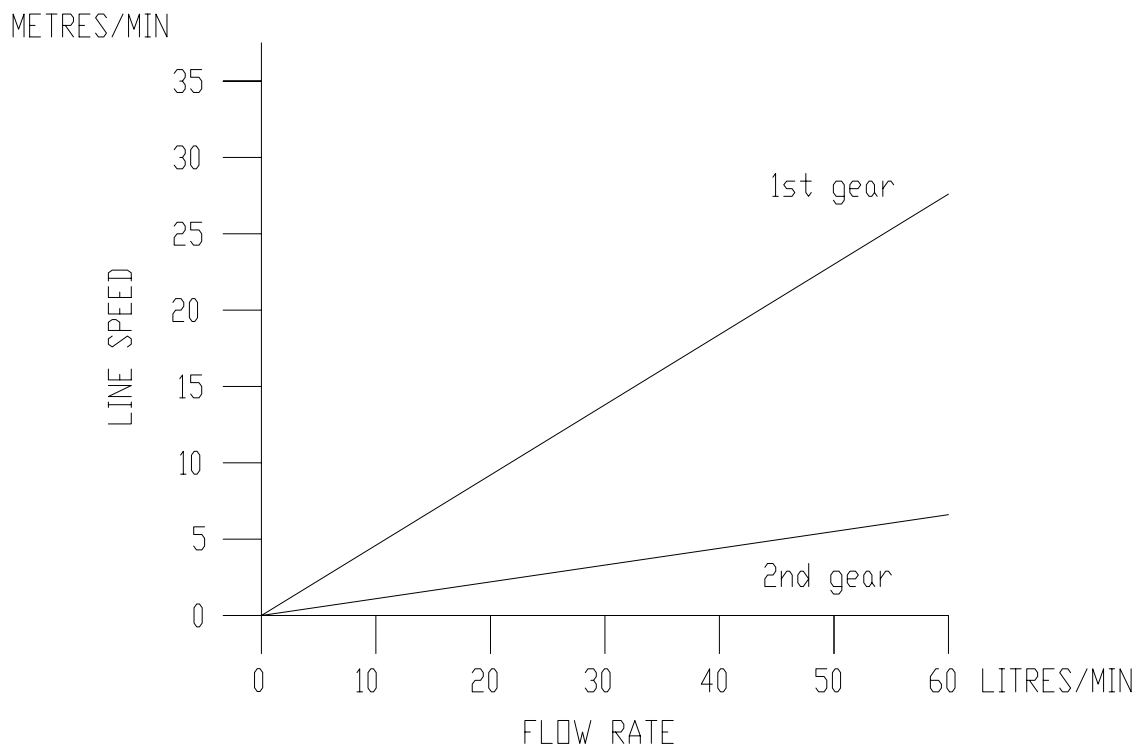
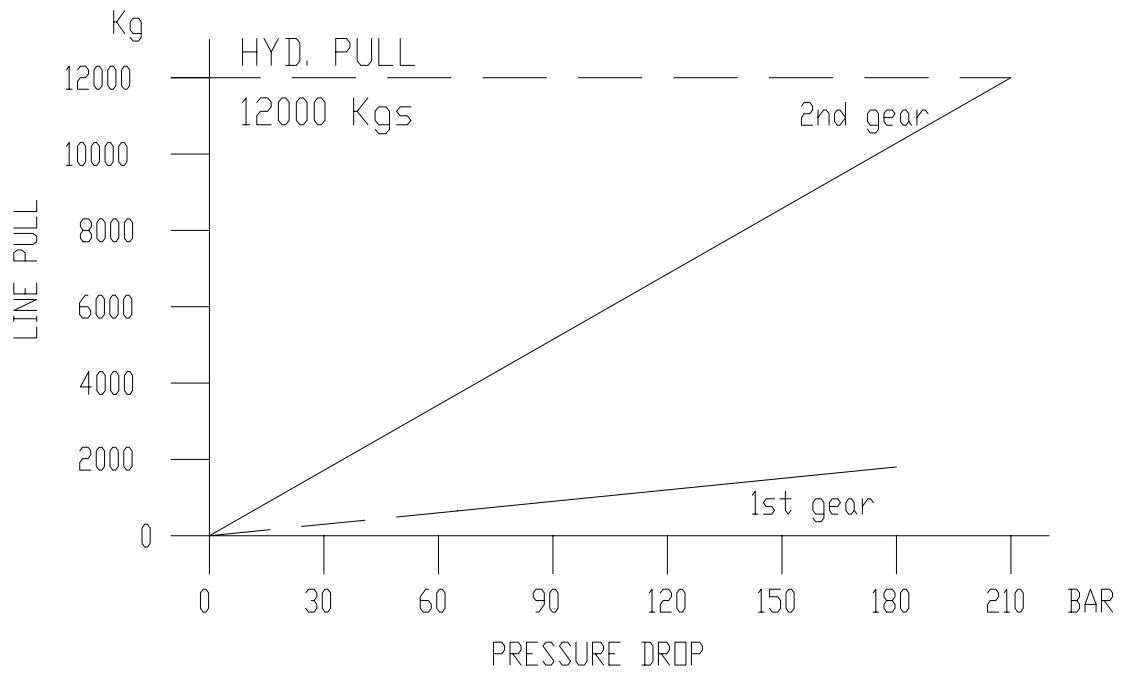

SAFE WORKING LOAD
12000 Kgs

ISSUE	REVISIONS	MOD No.
H	16.01.03 D.J.P	9096
G	20.12.02 D.J.P	9085
F	04.07.02 D.J.P	8939
E	15.02.02 D.J.P	8805

NOTES

1

B9521/B9707 SOLENOID CHART		
	1ST GEAR FAST	2ND GEAR SLOW
LMS125/2	-	+
LMS150/2	-	+

2 MAX PRESSURE 190 BAR
MAX FLOW:
LMS 125/2: 55 L/MIN
LMS 150/2: 60 L/MIN

3 VALVE SETTINGS
VALVE SETTINGS INDICATED ARE FOR INITIAL SET UP ONLY AND MAY BE RE-ADJUSTED DURING SERVICE TO SUIT THE PARTICULAR WORKING REQUIREMENTS.

VALVE V1: THIS VALVE DETERMINES THE LOAD REQUIRED TO PULL THE LINE OFF THE WINCH WHEN IN REEL OUT MODE. THIS VALVE MUST BE SET SUFFICIENTLY LOW TO ENABLE THE LINE TO BE EASILY PULLED OUT BUT MUST NOT BE SET TOO LOW OR STOWING DRUM OVERRUN MAY OCCUR DURING HIGH SPEED PAYOUT. USE TEST POINT TP1 IN REEL IN MODE

VALVE V2: THIS VALVE ENSURES THAT THE STOWING DRUM IS PROVIDING A TAILING LOAD FOR THE HAULING DRUM AT REEL IN START UP. THIS VALVE MUST BE SET SUFFICIENTLY HIGH TO ENSURE THAT THE HAULING DRUMS DO NOT SLIP ON START UP BUT DOES NOT REQUIRE TO BE SET GREATER THAN APPROX 100 BAR TO AVOID UNNECESSARY POWER WASTAGE. USE TEST POINT TP1 OR TP2 IN REEL IN MODE.

VALVE V3: THIS IS A COUNTERBALANCE VALVE AND ENSURES THAT WHEN EASING HIGH LOADS THAT THE LOAD CANNOT RUN AWAY OR WHEN HAULING HIGH LOADS THAT THE LOAD JUMP BACK IS MINIMISED WHEN STOPPING. THIS VALVE MUST BE SET SUFFICIENTLY HIGH TO ENSURE A SMOOTH START AND STOP UNDER HIGH LOADS BUT DOES NOT REQUIRE TO BE SET GREATER THAN APPROX 100 BAR TO AVOID UNNECESSARY POWER WASTAGE. USE TEST POINT TP2 IN REEL OUT MODE

VALVE V4: THIS IS A PRESSURE REDUCER VALVE AND CAN BE USED TO LIMIT THE PRESSURE TO THE MOTOR PILOT PORT. THIS VALVE IS FACTORY PRESET TO MAXIMUM AND SHOULD NOT NORMALLY REQUIRE FURTHER ADJUSTMENT.

4 SEE SHEET 1 FOR LMS77/2 (2 SPEED)
SEE SHEET 2 FOR LMS111/2

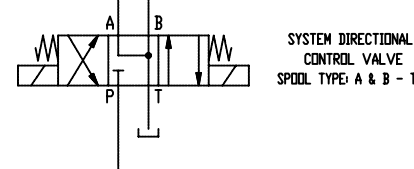
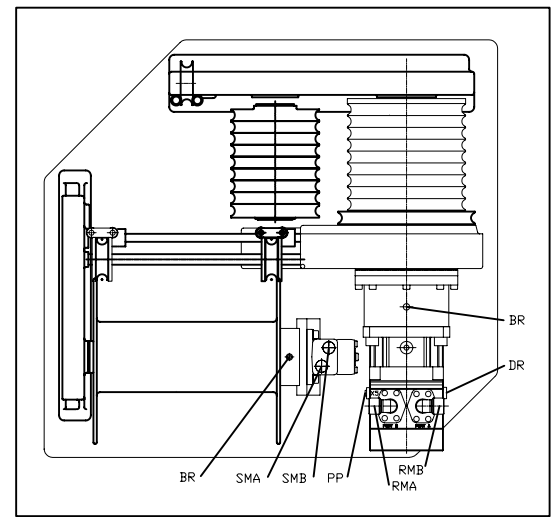
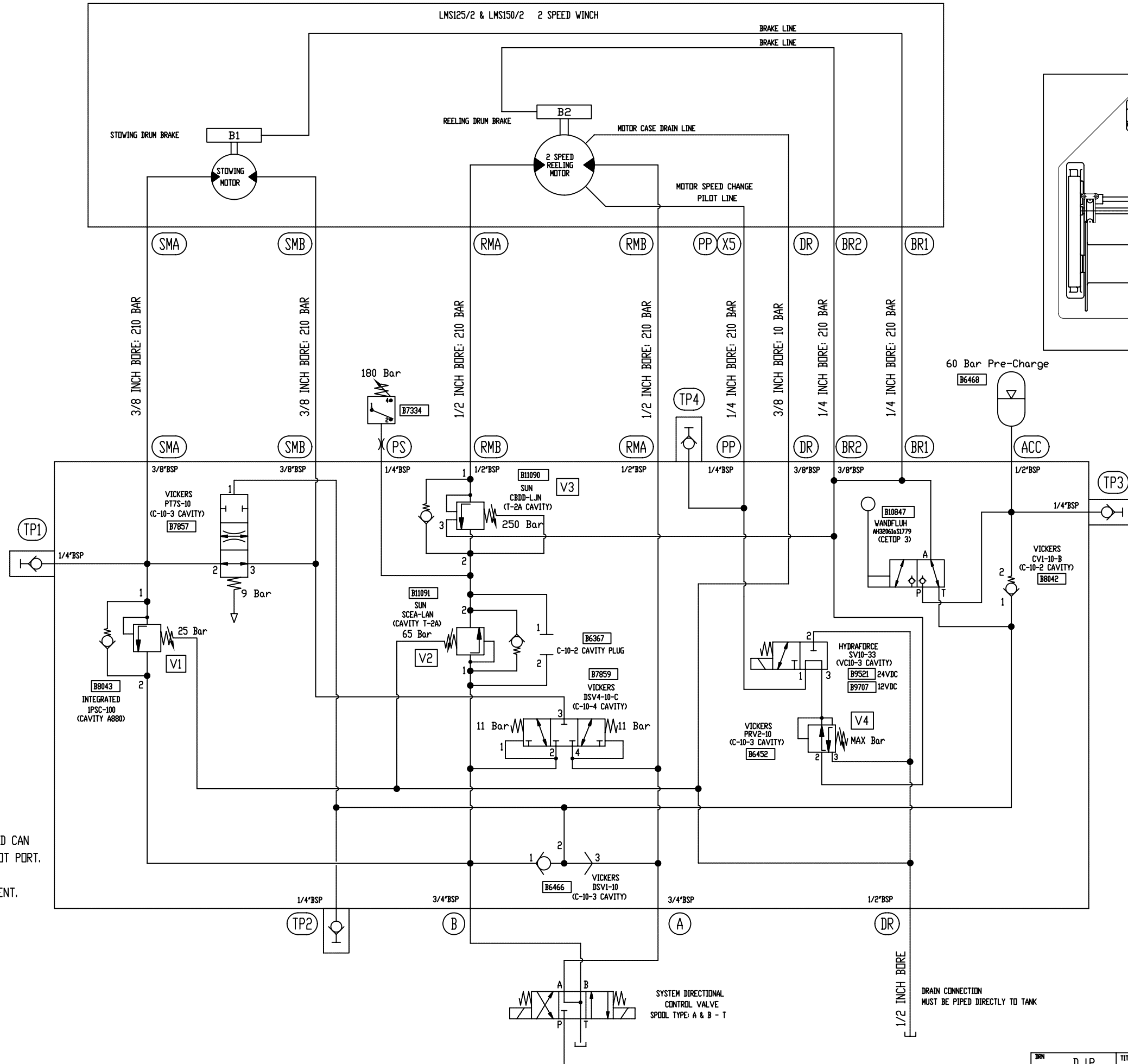

DRAIN CONNECTION MUST BE PIPED DIRECTLY TO TANK

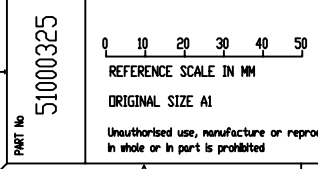

REF: MANIFOLD BLOCK PART NUMBER: 55200015
MANIFOLD BLOCK ASSY NUMBER (24V JIC VERSION): 58300829

LMS125/2 & LMS150/2

DRN	D.J.P	TITLE	LMS MANIFOLD BLOCK
CHL	-	PRODUCT	HYDRAULIC CIRCUIT
DATE	30.08.01	PART No.	51000325
SCALE	1:1		LEWMAR

FIRST ANGLE PROJECTION

REMOVE ALL BURRS AND SHARP EDGES

ISSUE	REVISIONS	DESIGNER	W.D. No.
D	04.07.02	D.J.P	8943
C	12.02.02	D.J.P	8799
B	12.10.01	D.J.P	8689
A	12.09.01	D.J.P	N/A

① FIT APPROX 20MM SUB FLUSH

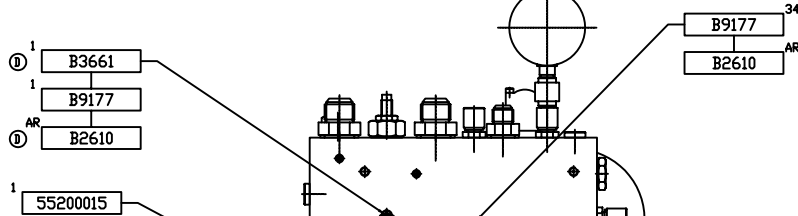

TORQUE CARTRIDGE TO 55-60 Nm

TORQUE CARTRIDGE TO 47-54 Nm

TORQUE TO 4-6 Nm

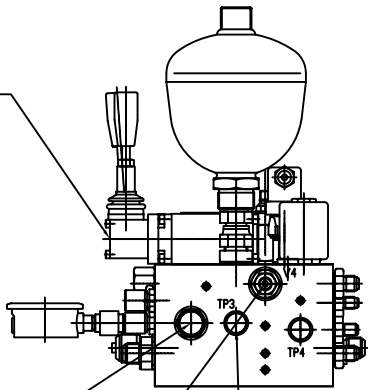

TORQUE CARTRIDGE TO 47-54 Nm

TORQUE CARTRIDGE TO 47-54 Nm

TORQUE CARTRIDGE TO 60-65 Nm

TORQUE CARTRIDGE TO 60-65 Nm

TORQUE CARTRIDGE TO 47-54 Nm

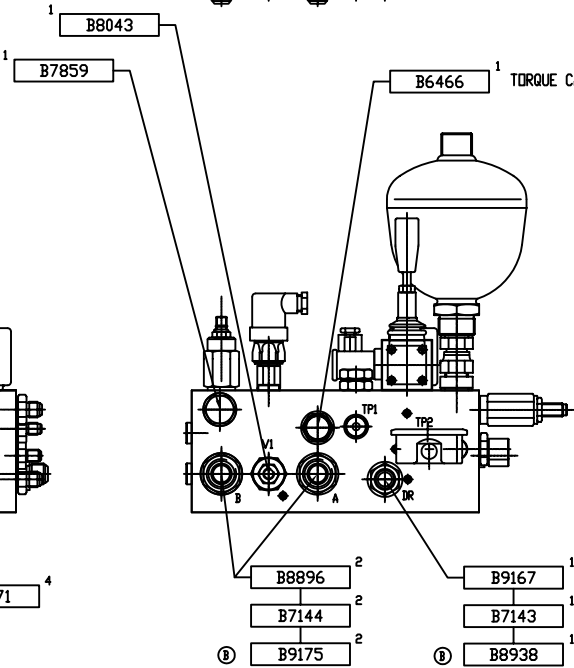

TORQUE CARTRIDGE TO 47-54 Nm

TORQUE PLUG TO 47-54 Nm

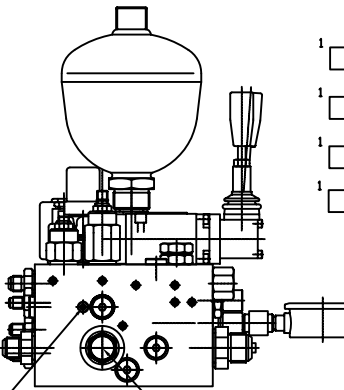

TORQUE PLUG TO 47-54 Nm

- ③ B9568
- ③ B8368
- ③ B9074

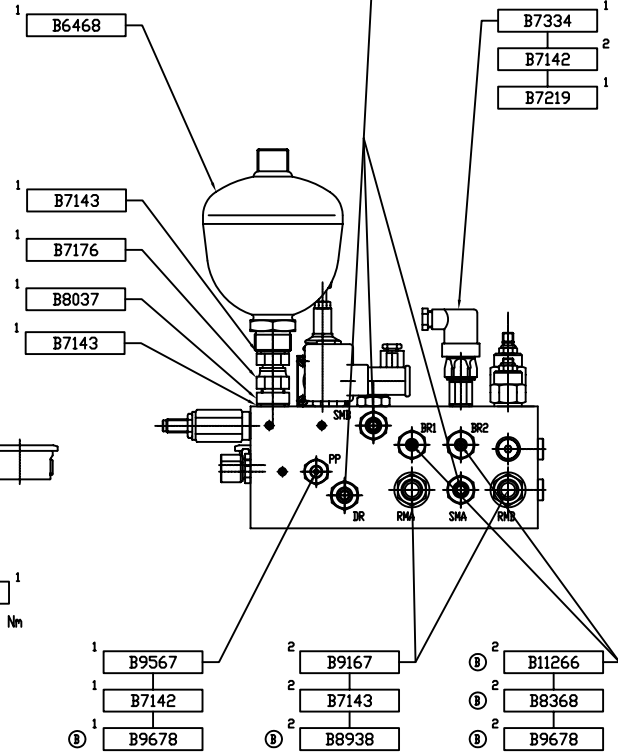

NOTE - SET VALVES AND PRESSURE SWITCH IN ACCORDANCE WITH CIRCUIT DIAGRAM 51000325 TO SUIT WINCH MODEL

SHEET NO. 1 OF 1

58300829

REFERENCE SCALE IN MM
ORIGINAL SIZE A1

Unauthorized use, manufacture or reproduction
in whole or in part is prohibited

INTERNAL FINISH CLEAN	TOLERANCES UNLESS STATED	DESIGNER D.J.P CHK. - DATE 12.09.01 SCALE 1:2.5	TITLE PRODUCT LMS MANIFOLD BLOCK ASSY 24V JIC LMS	PART NO. 58300829	LEWMAIR
-----------------------------	--------------------------	--	--	----------------------	---------

FIRST ANGLE PROJECTION

REMOVE ALL BURRS AND SHARP EDGES

ISSUE	REVISED	BY	NO.
D	04.07.02	D.J.P	8943
C	12.02.02	D.J.P	8799
B	12.10.01	D.J.P	8689
A	12.09.01	D.J.P	N/A

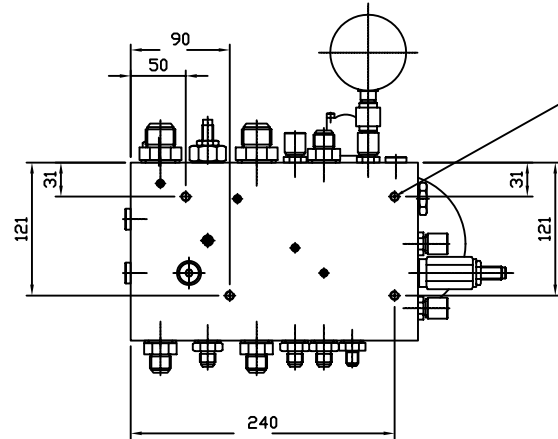

4 OFF MOUNTING HOLES
THREADED M8 x 12 DEEP

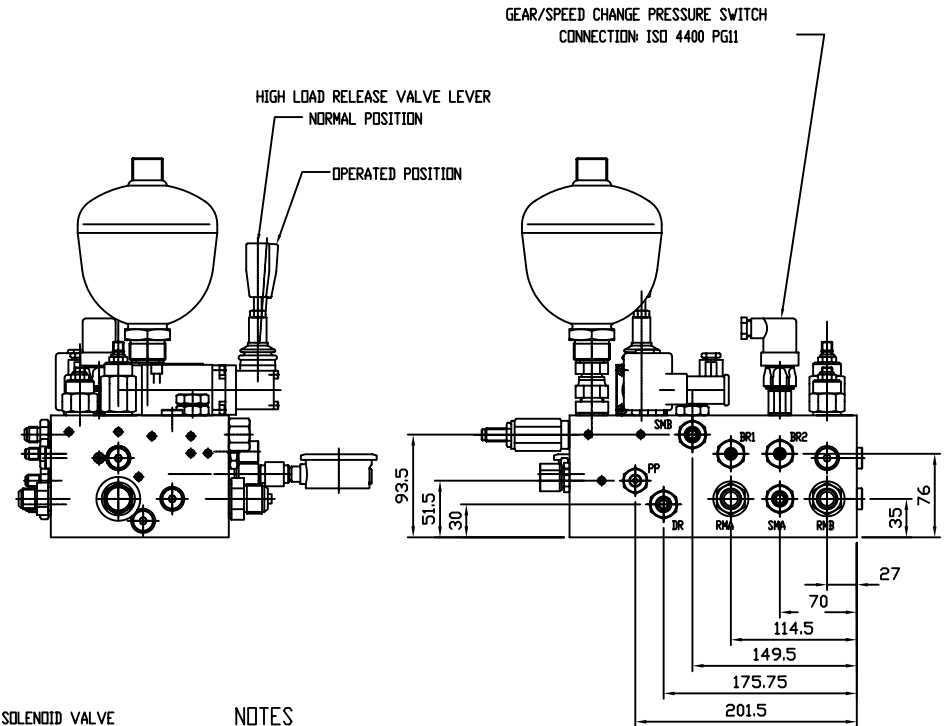
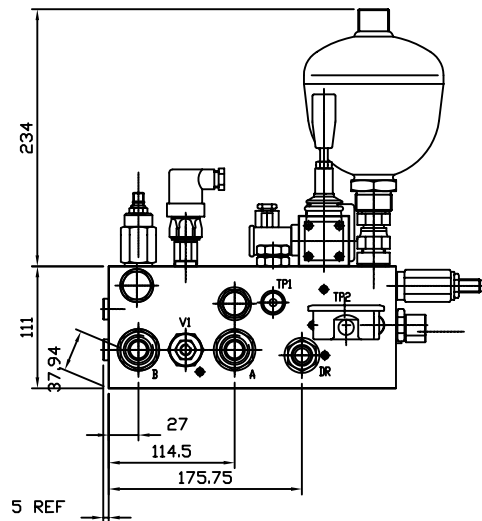
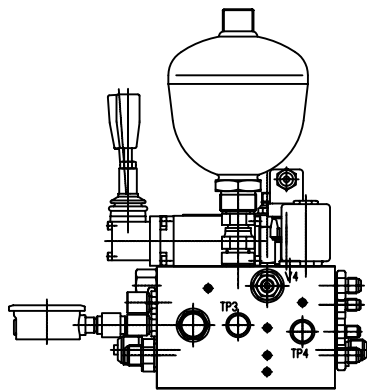

CONNECTION SIZES:

SYSTEM TO BLOCK

- A & B - 1-1/16"x12 JIC (DASH-12)
- DR - 3/4"x16 JIC (DASH-8)

BLOCK TO LMS WINCH

- RMA & RMB - 3/4"x16 JIC (DASH-8)
- SMA, SMB, DR - 9/16"x18 JIC (DASH-6)
- PP - 7/16"x20 JIC (DASH-4)
- BR1 & BR2 - 7/16"x20 JIC (DASH-4)

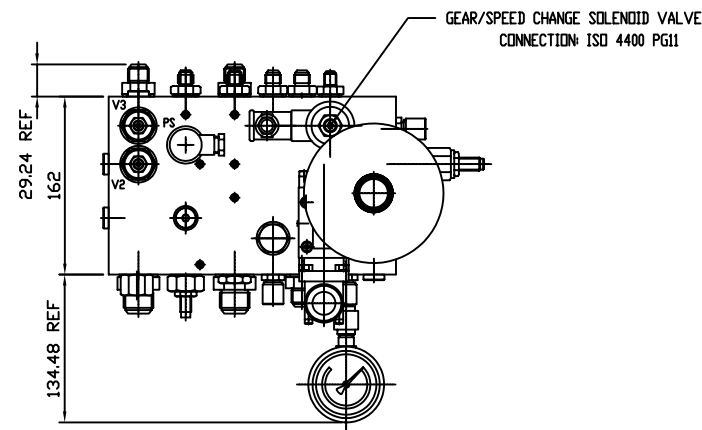

NOTES

- ACCUMULATOR HAS 60 BAR NITROGEN PRE-CHARGE BEFORE DISCONNECTING ANY VALVE OR FITTING ENSURE THE ACCUMULATOR IS FULLY DISCHARGED OF HYDRAULIC OIL BY OPERATING THE EMERGENCY RELEASE VALVE A MINIMUM OF 20 TIMES
- ALL HYDRAULIC CONNECTOR/ADAPTORS ARE STAINLESS STEEL
- MOUNTING ATTITUDE - UNRESTRICTED
- REFER TO HYDRAULIC CIRCUIT DIAGRAM 51000325 FOR FULL HYDRAULIC SYSTEM DETAILS AND VALVE ADJUSTMENTS
- MAX FLOW APPROX 90 L/MIN
MAX PRESSURE 210 BAR
- APPROX DRY WEIGHT: 18 KG

SHEET NO. 2 OF 2

REF ID: 58300829

0 10 20 30 40 50

REFERENCE SCALE IN MM

ORIGINAL SIZE A1

Unauthorized use, manufacture or reproduction in whole or in part is prohibited

INTERNAL	TOLERANCES UNLESS STATED	BY D.J.P	TITLE	LMS MANIFOLD BLOCK ASSY 24V JIC
FINISH		CHK -	PRODUCT	LMS
CLEAN		DATE 12.09.01	PART NO	58300829
	ALL DIMENSIONS IN MM	SCALE 1:2.5		LEWMAIR

Unauthorised use, manufacture or reproduction
in whole or in part is prohibited.

PART No
58400667

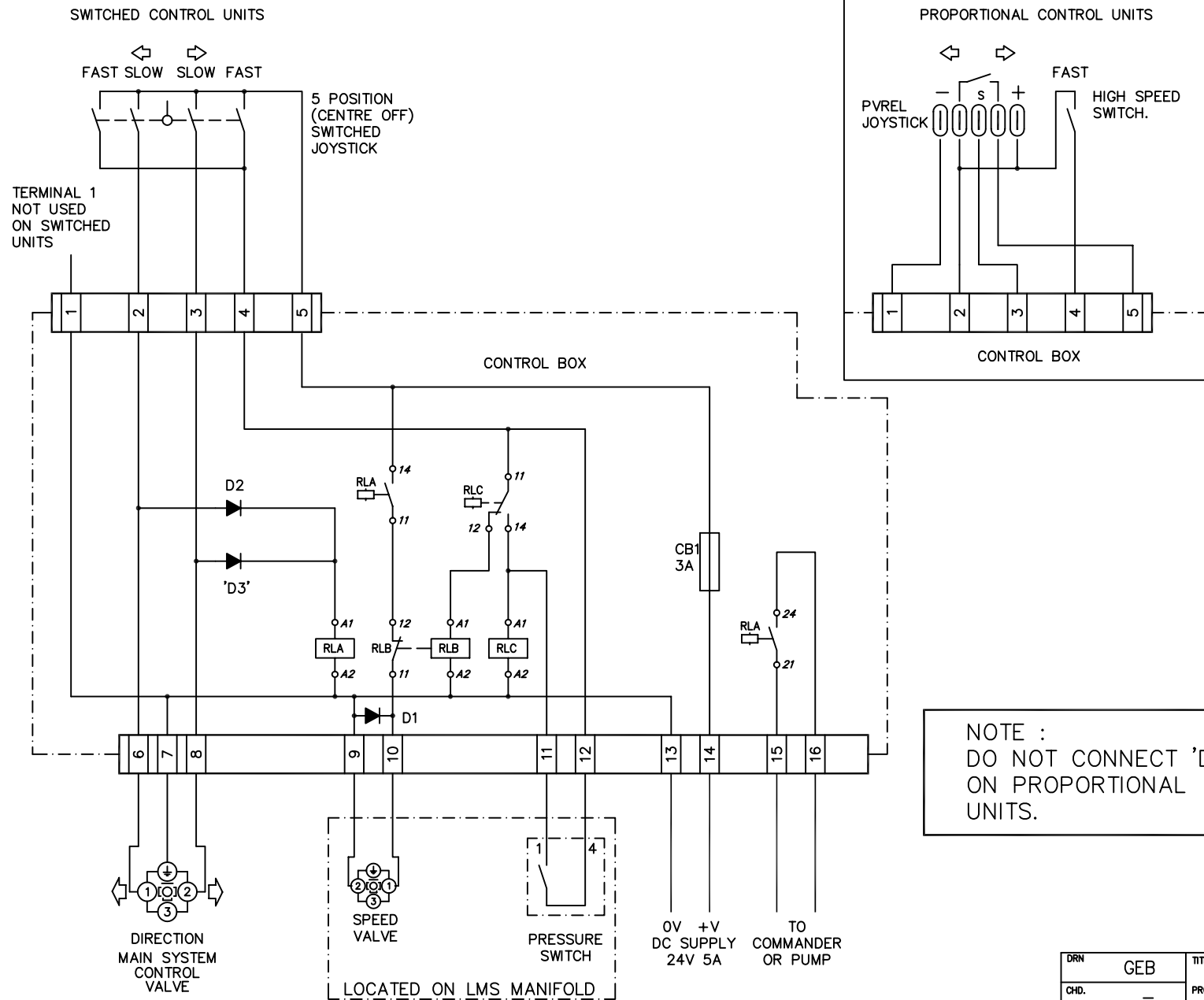

NOTE :
DO NOT CONNECT 'D3'
ON PROPORTIONAL
UNITS.

ISSUE	REVISIONS	MOD No.
A	21.02.06	GEB

SHEET 1 OF 1

DRN	GEB	TITLE	LMS CONTROL CIRCUIT
CHD.	-	PRODUCT	CUSTOM CONTROL
DATE	21.02.06	PART No	58400667
SCALE			LEWMAR

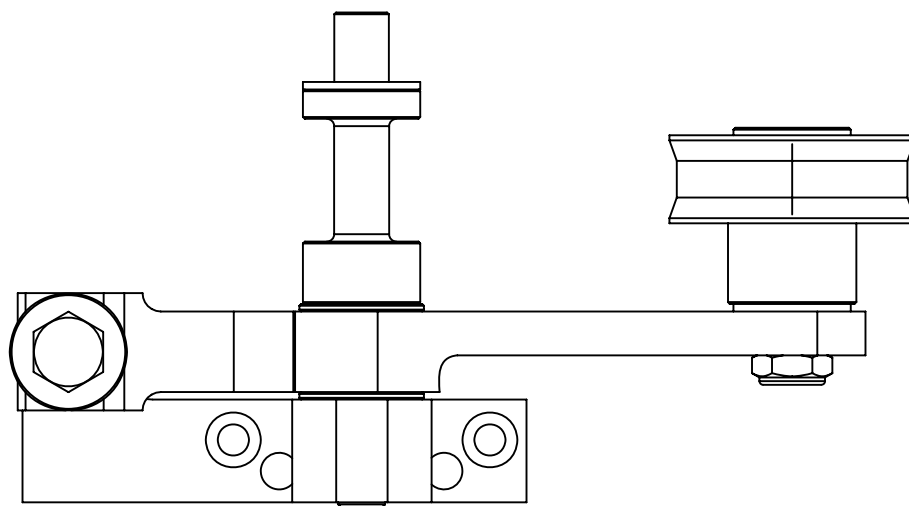
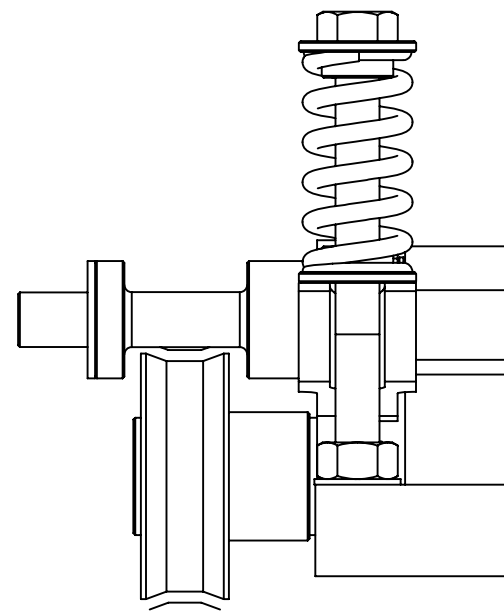
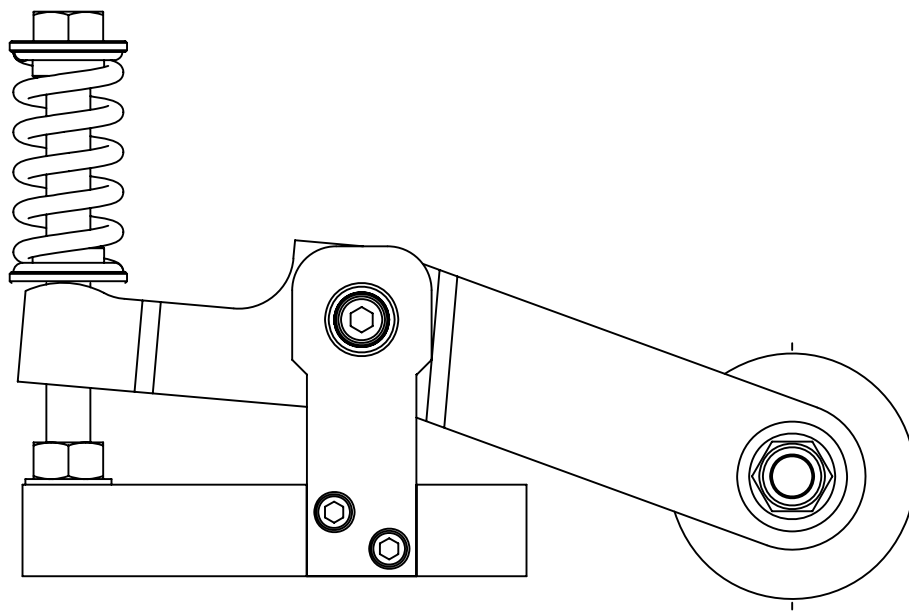
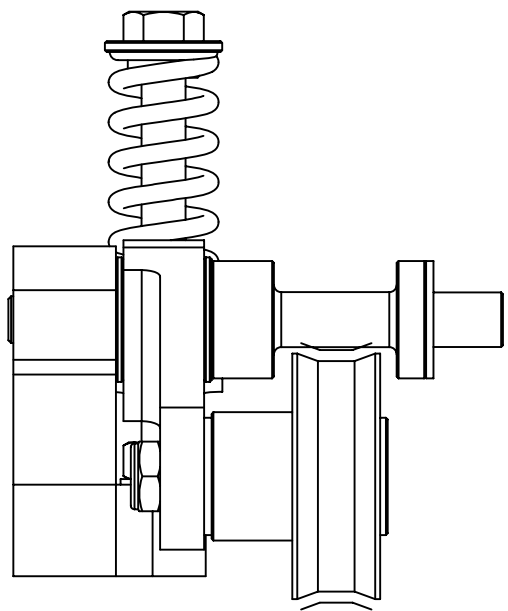

58600076

ISSUE	REVISIONS	MOD No.
B		

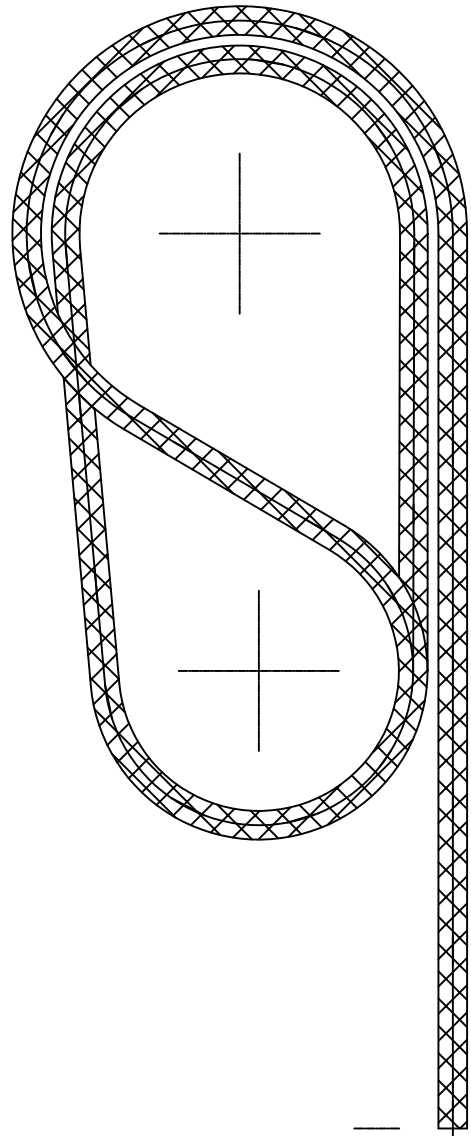

ROPE ENTRY

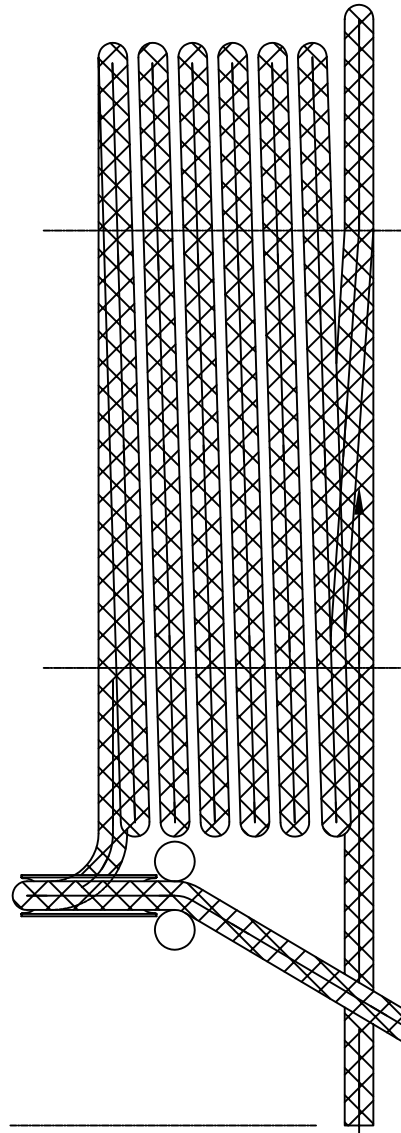

ROPE ENTRY

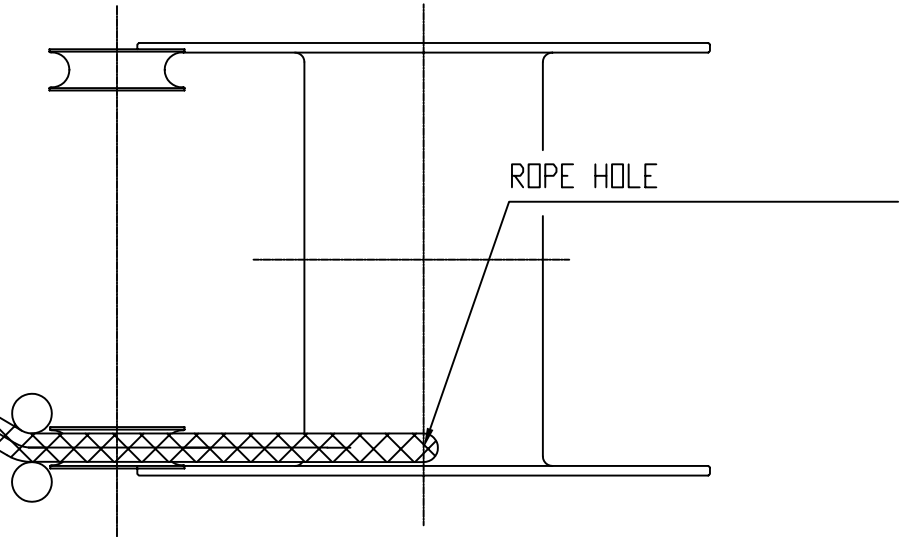

ROPE HOLE

LEWMAR COMPUTER DESIGN

55600173

PART No

Unauthorised use, manufacture or reproduction
in whole or in part is prohibited

DRN L MOORE	TITLE LMS ROPE PATH	
CHD.		
DATE 02.04.93.	PART No 55600173	LEWMAR
SCALE N.T.S.		



NOTES



NOTES



NOTES



LIMITED WARRANTY and KEY TERMS OF SUPPLY BY LEWMAR

Lewmar warrants that in normal usage and with proper maintenance its products will conform with their specification for a period of three years from the date of purchase by the end user, subject to the conditions, limitations and exceptions listed below. Any product, which proves to be defective in normal usage during that three-year period, will be repaired or, at Lewmar's option, replaced by Lewmar.

A CONDITIONS AND LIMITATIONS

- i Lewmar's liability shall be limited to the repair or replacement of any parts of the product which are defective in materials or workmanship.
- ii Responsibility for the selection of products appropriate for the use intended by the Buyer shall rest solely with the Buyer and Lewmar accepts no responsibility for any such selection.
- iii Lewmar shall not be liable in any way for Product failure, or any resulting loss or damage which arises from:
 - a use of a product in an application for which it was not designed or intended;
 - b corrosion, ultra violet degradation or wear and tear;
 - c a failure to service or maintain the product in accordance with Lewmar's recommendations;
 - d faulty or deficient installation of the product (unless conducted by Lewmar);
 - e any modification or alteration of the product;
 - f conditions that exceed the product's performance specifications or safe working loads.
- iv Product subject to a warranty claim must be returned to the Lewmar outlet which supplied the product for examination unless otherwise agreed by Lewmar in writing.
- v This warranty does not cover any incidental costs incurred for the investigation, removal, carriage, transport or installation of product.
- vi Service by anyone other than authorised Lewmar representatives shall void this warranty unless it accords with Lewmar guidelines and standards of workmanship.
- vii Lewmar's products are intended for use only in the marine environment. Buyers intending to use them for any other purpose should seek independent professional advice as to their suitability. Lewmar accepts no liability arising from such other use.



B EXCEPTIONS

Cover under this Warranty is limited to a period of one year from the date of purchase by the end user in the case of any of the following products or parts of products:

- Electric motors and associated electrical equipment
- Electronic controls
- Hydraulic pumps, valves and actuators
- Weather seals
- Products used in "Grand Prix" racing applications

C LIABILITY

i Lewmar's liability under this warranty shall be to the exclusion of all other warranties or liabilities (to the extent permitted by law). In particular (but without limitation):

a Lewmar shall not be liable for:

- Any loss of anticipated turnover or profit or indirect, consequential or economic loss ;
- Damages, costs or expenses payable to any third party;
- Any damage to yachts or equipment;
- Death or personal Injury (unless caused by Lewmar's negligence).

Some states and countries do not allow the exclusion or limitation of incidental or consequential damages, so the above limitation or exclusion may not apply to you.

b Lewmar grants no other warranties regarding the fitness for purpose, use, nature or satisfactory quality of the products.

ii Where applicable law does not permit a statutory or implied warranty to be excluded, then such warranty, if permitted by that state or country's law, shall be limited to a period of one year from the date of purchase by the end user. Some states and countries do not allow limitations on how long an implied warranty lasts, so this limitation may not apply to you.

D PROCEDURE

Notice of a claim for service under this warranty shall be made promptly and in writing by the end user to the Lewmar outlet which supplied the product or to Lewmar at Southmoor Lane, Havant, Hampshire, England PO9 1JJ.

E SEVERANCE CLAUSE

If any clause of this warranty is held by any court or other competent authority to be invalid or unenforceable in whole or in part, the validity of the remaining clauses of this warranty and the remainder of the clause in question shall not be affected.



F OTHER RIGHTS

This warranty gives you specific legal rights, and you may also have other legal rights, which vary, from state to state and country to country.

In the case of European States a Consumer customer (as defined nationally) has legal rights under the applicable national law governing the sale of Consumer Goods; this Warranty does not affect those rights.

G LAW

This warranty shall be governed by and read in accordance with the laws of England or the state or country in which the first end user is domiciled at the time of purchase of the product.

H DISPUTES

Any dispute arising under this warranty may, at the option of the end-user, be referred to alternative dispute resolution under the rules of the British Marine Federation or to the Courts of the State whose law shall govern the warranty or to the Courts of England and Wales.

The British Marine Federation may be contacted at Marine House, Thorpe Lea Road, Egham, England, TW20 8BF



UK & International Distribution

Southmoor Lane, Havant
Hampshire
PO9 1JJ
England

Tel: +44 (0)23 9247 1841
Fax: +44 (0)23 9248 5720
Email: info@lewmar.com

USA

351 New Whitfield Street
Guilford, CT
06437
USA

Tel: +1 203 458 6200
Fax: +1 203 453 5669
Email: info@lewmarusa.com

Northern Europe

Popovstraat 12
8013 RK
Zwolle
Netherlands

Tel: +31 (0)38 427 34 90
Fax: +31 (0)38 421 56 42
Email: info@holland.lewmar.com

Southern Europe

18 rue Leonard de Vinci
Z.A.C Belle Aire Nord
17440 Aytre
France

Tel: +33 5 46 50 50 46
Fax: +33 5 46 50 59 04
Email: info@france.lewmar.com

Australia

Unit 4, 224 Headland Road
Dee Why 2099, NSW
Australia

Tel: +61 29 936 7111
Fax: +61 29936 7112
Email: info@lewmar.com.au
